



INSTALLATION INSTRUCTIONS FOR PART 95-6511

APPLICATIONS

See application list inside

Chrysler multi-kit 2007-up 95-6511



KIT FEATURES

- Double DIN head unit provision
- Stacked ISO head unit provision

KIT COMPONENTS

- A) Double DIN brackets/trim plate

A

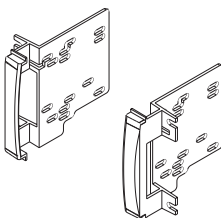

WIRING & ANTENNA CONNECTIONS (sold separately)

Wiring Harness:

- XSVI-6522-NAV Chrysler CAN RAP harness 2007-up
- CHT0-03 Chrysler CAN AMP harness 2007-up

Antenna Adapter:

- 40-EU10 European antenna adapter 2002-up

TOOLS REQUIRED

- Panel removal tool • Phillips screwdriver • Small flat blade screwdriver • Socket set



METRA. THE WORLD'S BEST KITS.™



1-800-221-0932



metraonline.com

© COPYRIGHT 2004-2011 METRA ELECTRONICS CORPORATION

INST95-6511

REV. 5/17/12



95-6511

Applications

Chrysler

200	2011-up
300/300C	2008-2010
Aspen	2008-2009
Sebring	2007-2010
Town and Country	2008-up

Dodge

Avenger	2007-up
Caliber	2009-up
Challenger	2008-up
Charger	2008-2010

Dodge (continued)

Dakota	2008-2011
Durango	2008-2010
Grand Caravan	2008-up
Journey**	2009-2010
Magnum	2008
Nitro	2007-2011
Ram 1500	2009-up
Ram 2500/3500	2010-up

Jeep

Compass	2009-up
---------	---------

Jeep (continued)

Commander	2008-2010
Grand Cherokee	2008-2010
Patriot	2009-up
Liberty	2008-up
Wrangler**	2007-2010

Mitsubishi

Raider	2008-2009
--------	-----------

VW

Routan	2009-up
--------	---------

***(Modifications to radio cavity required)*

CAUTION: Metra recommends disconnecting the negative battery terminal before beginning any installation. All accessories, switches, and especially air bag indicator lights must be plugged in before reconnecting the battery or cycling the ignition.

Note: Refer to the instructions included with the aftermarket radio.



KNOWLEDGE IS POWER

Enhance your installation and fabrication skills by enrolling in the most recognized and respected mobile electronics school in our industry. Log onto www.installerinstitute.com or call 800-354-6782 for more information and take steps toward a better tomorrow.



Metra recommends MECP certified technicians



95-6511

Table of Contents

Dash Disassembly

– Chrysler Aspen 2008-2009/Dodge Durango 2008-2010	4
– Chrysler Sebring 2007-2010	5
– Chrysler Town and Country 2008-2010.....	6-7
– Chrysler Town and Country 2011-up.....	8
– Chrysler 200 2011-up	9
– Chrysler 300/300c 2008-2010	10
– Dodge Magnum 2008/Charger 2008-2010	10
– Dodge Avenger 2007-up.....	11
– Dodge Dakota 2008-2011	12
– Dodge Nitro 2007-2011/Jeep Liberty 2008-up	13
– Dodge Journey 2009-2010**	14
– Dodge Caliber 2009-up.....	15
– Dodge Challenger 2009-up.....	15
– Dodge Grand Caravan 2008-2010	6-7
– Dodge Grand Caravan 2011-up	8
– Dodge Ram 1500 2009-up	16-18
– Dodge Ram 2500/3500 2010-up	16-18
– Jeep Compass 2009-up.....	15
– Jeep Patriot 2009-up	15
– Jeep Commander/Grand Cherokee 2008-2010.....	19
– Jeep Wrangler 2007-2010**	20
– Mitsubishi Raider 2008-2009	21
– VW Routan 2009-up.....	8

Kit Assembly

– Double DIN head unit provision	22
– Stacked ISO DIN head unit provision	22

*** (Modifications to radio cavity required)*



Dash Disassembly 95-6511

Chrysler Aspen 2008-2009 Dodge Durango 2008-2010

1. Unsnap and remove storage cup holder assembly. (Figure A)
2. Remove (2) screws from bottom edge of center dash trim panel. Unsnap and remove the panel. (Figure B)
3. Remove (4) screws securing the radio. Unplug and remove radio. (Figure C)

Continue to kit assembly

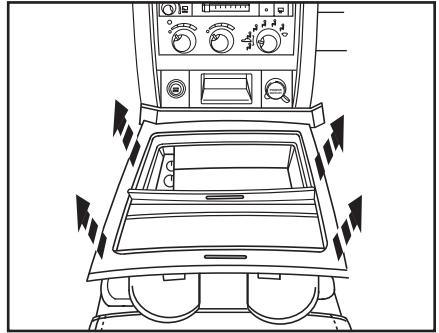

(Figure A)

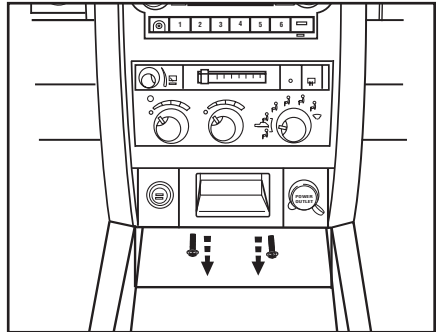

(Figure B)

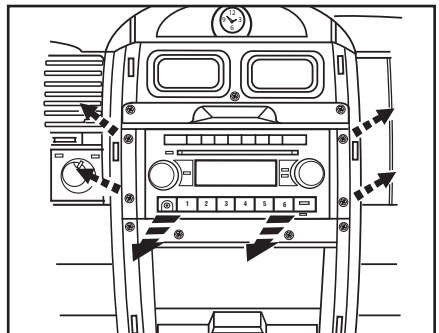

(Figure C)

Chrysler Sebring 2007-2010

1. Unclip entire panel surrounding radio including A/C vents and clock. Unplug and remove panel. (Figure A)
2. Remove (4) 7 mm screws securing radio. Unplug and remove radio. (Figure B)

Continue to kit assembly

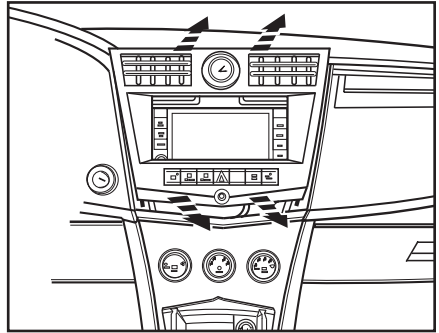

(Figure A)

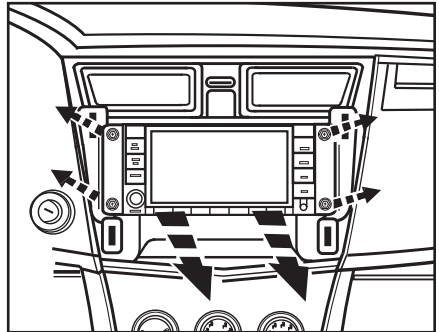

(Figure B)

Chrysler Town and Country 2008-2010 Dodge Grand Caravan 2008-2010

1. Remove (2) screw covers facing up above radio then remove the (2) Phillips screws exposed. (Figure A)
2. Lift up on panel above radio then remove (2) Phillips screws exposed at front edge of radio trim panel. (Figure B)
3. Remove (3) plastic push pins per side of bottom trim panel then slide panel toward rear of van to access (2) screws on bottom of radio trim panel. (Figure C)

Continued on next page

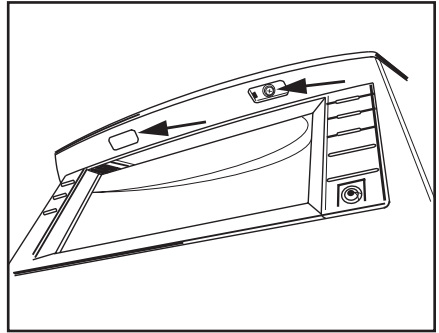

(Figure A)

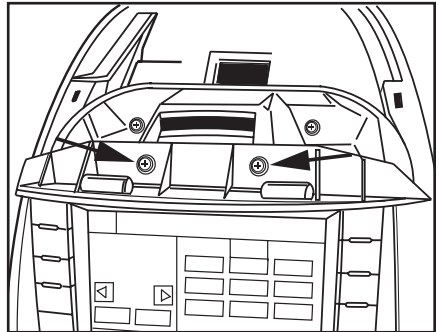

(Figure B)

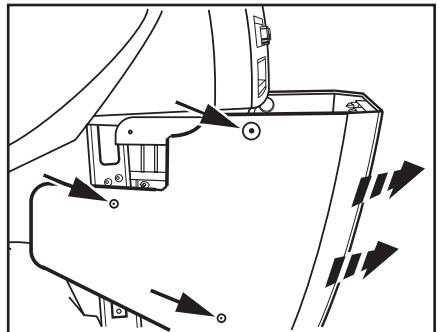

(Figure C)

Chrysler Town and Country 2008-2010 Dodge Grand Caravan 2008-2010

4. Remove (2) Phillips screws exposed at bottom edge radio trim panel. (Figure D)
5. Unclip and remove entire panel surrounding radio including climate controls, vents and clock. (Figure E)
6. Remove (4) Phillips screws securing radio. (Figure F)

Continue to kit assembly

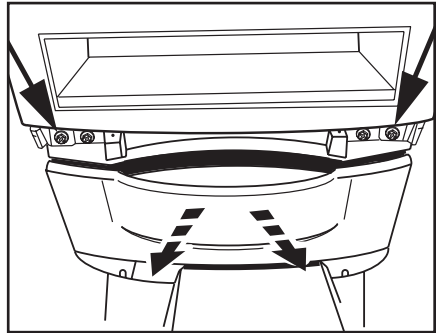

(Figure D)

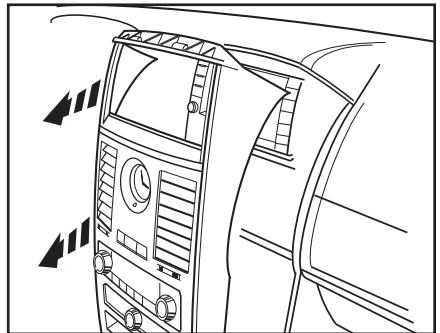

(Figure E)

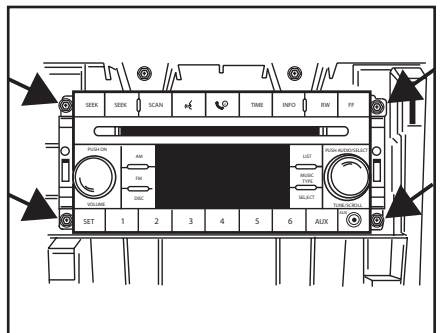

(Figure F)



Dash Disassembly 95-6511

Chrysler Town and Country 2011-up Dodge Grand Caravan 2011-up Volkswagen Routan 2009-up

1. Unclip and remove the radio trim panel.
(Figure A)
2. Remove (4) Torx securing the radio.
(Figure B)

Continue to kit assembly

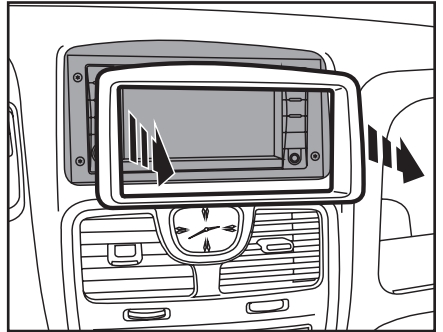

(Figure A)

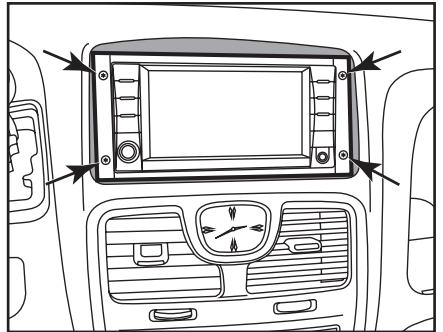

(Figure B)

Chrysler 200 2011-up

1. Unclip and remove the radio trim panel.
(Figure A)
2. Remove (4) Torx securing the radio.
(Figure B)

Continue to kit assembly

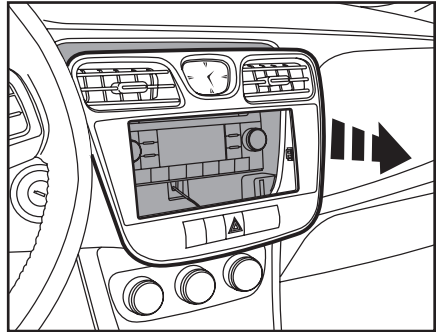

(Figure A)

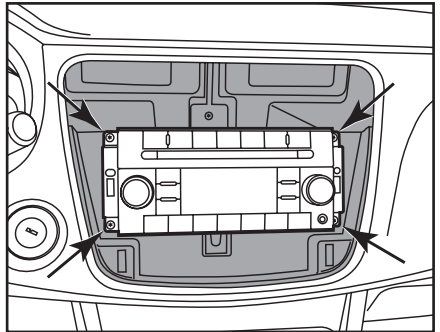

(Figure B)



Dash Disassembly 95-6511

Chrysler 300/300C 2008-2010 Dodge Magnum 2008 Dodge Charger 2008-2010

1. Unsnap and remove center dash trim panel. (Figure A)
2. Remove (4) screws securing the radio. Disconnect and remove the radio. (Figure B)

Continue to kit assembly

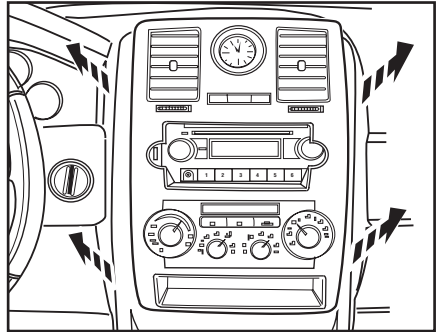

(Figure A)

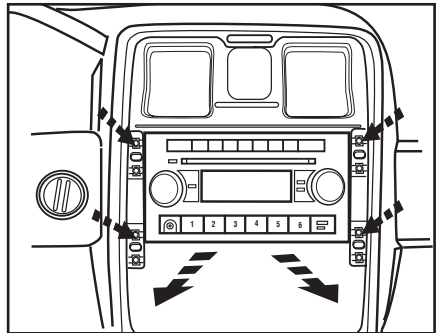

(Figure B)

Dodge Avenger 2007-up

1. Unclip and remove the center console trim panel. (Figure A)
2. Unclip the center dash trim panel. (Figure B)
3. Remove (4) screws securing the radio. Disconnect and remove the radio. (Figure C)
4. Remove (3) screws securing the radio rear support bracket and remove the bracket. (Figure D)

Continue to kit assembly

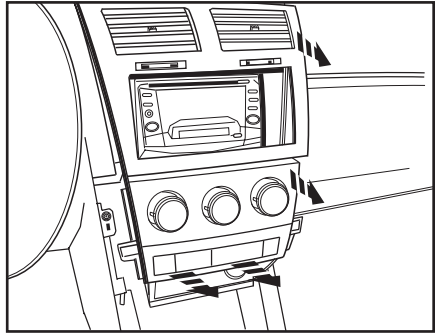

(Figure B)

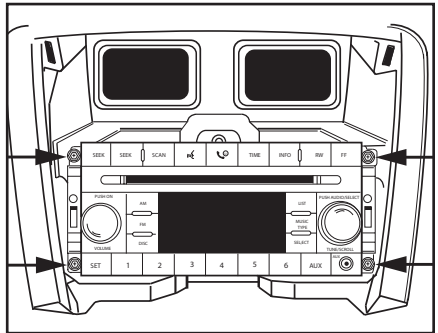

(Figure C)

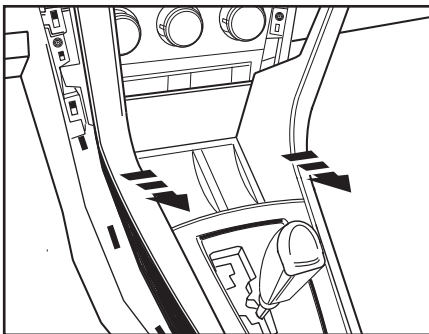

(Figure A)

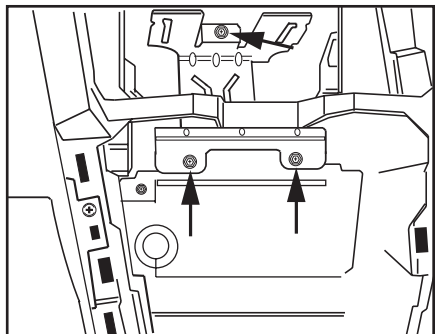

(Figure D)



Dash Disassembly 95-6511

Dodge Dakota 2008-2011

1. Unclip and remove the trim panel surrounding the radio. (Figure A)
2. Remove (4) Phillips screws securing the radio. (Figure B)

Continue to kit assembly

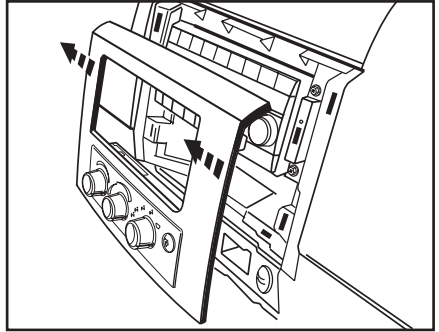

(Figure A)

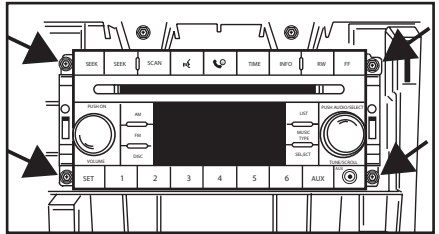

(Figure B)



Dash Disassembly 95-6511

Dodge Nitro 2007-2011 Jeep Liberty 2008-up

1. Unclip entire panel surrounding radio and climate controls, including A/C vents. Unplug and remove panel. (Figure A)
2. Remove (4) 7 mm screws securing radio. Unplug and remove radio. (Figure B)

Continue to kit assembly

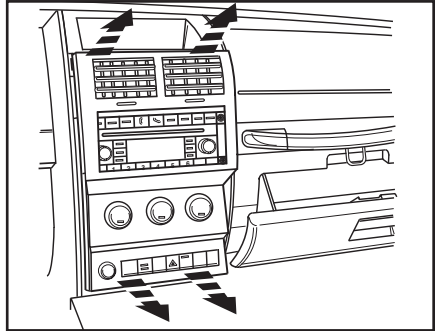

(Figure A)

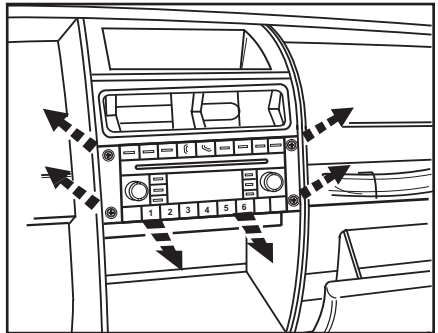

(Figure B)

Dodge Journey 2009-2010

(Modifications to radio cavity required)

1. Unclip and remove the entire factory radio trim panel including the A/C controls. (Figure A)

TIP: Open the compartment door at the top of the radio trim panel.

2. Remove (4) 7 mm screws securing radio to dash to remove. (Figure B)

NOTE: The top of the metal bracket in the sub dash will need to be cut to allow for the clearance of the Double DIN radio's chassis. (Figure C)

Continue to kit assembly

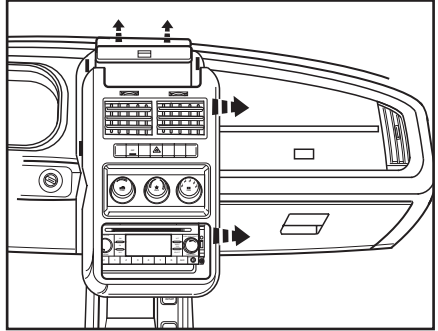

(Figure A)

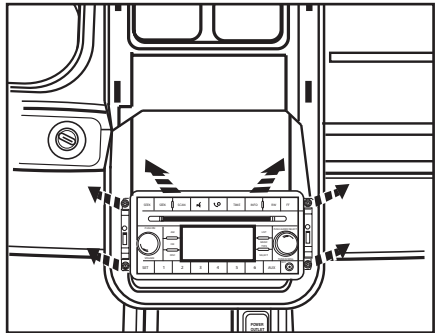

(Figure B)

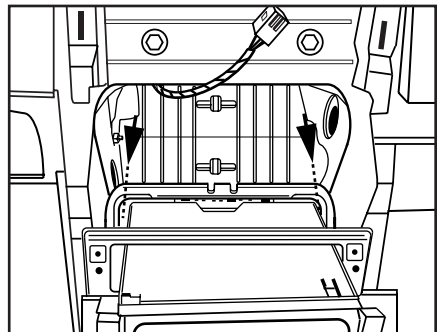

(Figure C)

Dodge Caliber 2009-up Dodge Challenger 2009-up Jeep Compass 2009-up Jeep Patriot 2009-up

1. Unsnap and move shifter trim to the side. (Figure A)
2. Unsnap center dash trim panel (do not remove until climate controls are removed). (Figure A)
3. Remove (4) Phillips screws holding climate control panel to backside of the center dash panel.
4. Remove (4) 7 mm screws securing radio. Unplug and remove radio.
5. The metal bracket in the sub-dash will need to be removed for the aftermarket Double DIN radio's depth.

Continue to kit assembly

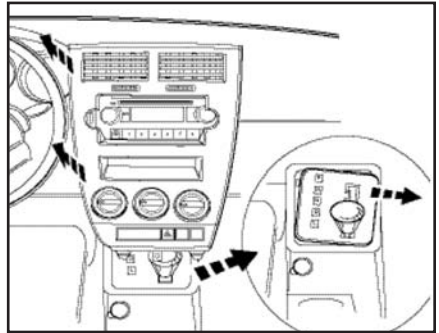

(Figure A)



Dash Disassembly 95-6511

Dodge Ram 1500 2009-up Dodge Ram 2500/3500 2010-up

1. Remove (1) T25 Torx screw in the compartment next to the cup holders. (Figure A)
2. Remove (2) Phillips screws in the pocket below the climate control in the front of the center console. (Figure B)
3. Remove (2) 9/32" screws in the cup holders. (Figure C)

Continued on next page

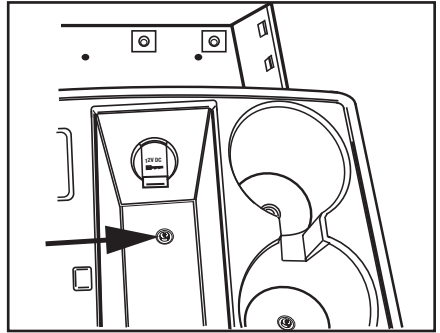

(Figure A)

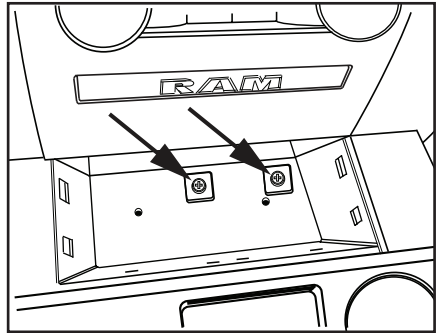

(Figure B)

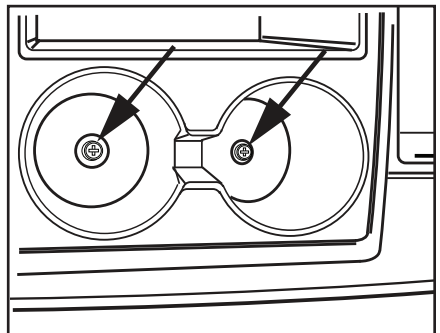

(Figure C)

Dodge Ram 1500 2009-up Dodge Ram 2500/3500 2010-up

4. Push down on the collar below the shifter then pull the shifter straight up to remove. (Figure D)
5. Unclip and remove the top of the center console including the cup holders. (Figure E)
6. Unclip and remove the trim panel from the accessory socket on the radio trim panel, then remove (1) T25 Torx screw. (Figure F)

Continued on next page

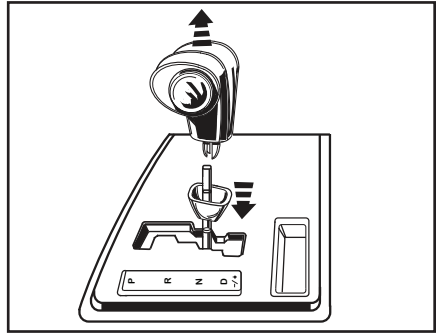

(Figure D)

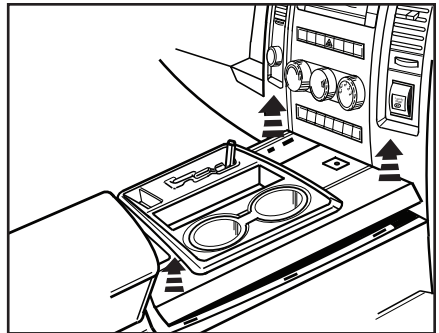

(Figure E)

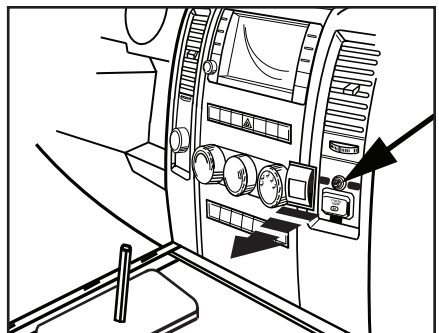

(Figure F)



Dash Disassembly 95-6511

Dodge Ram 1500 2009-up Dodge Ram 2500/3500 2010-up

7. Remove (2) T25 Torx screws from the top of the radio trim panel. (Figure G)
8. Unclip and remove the entire radio trim panel including the climate controls. (Figure H)
9. Remove (4) 9/32" screws securing the radio. (Figure I)

Continue to kit assembly

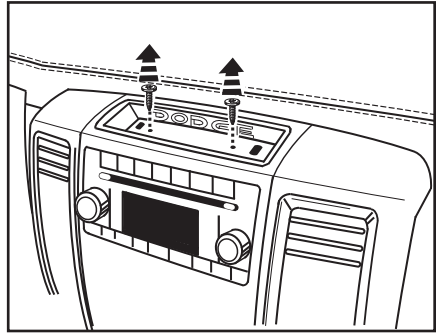

(Figure G)

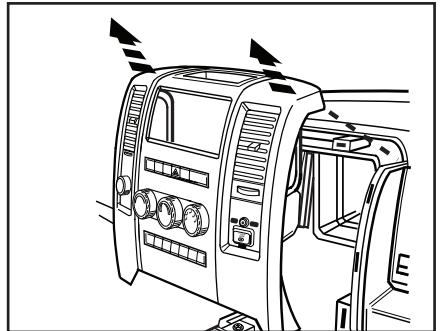

(Figure H)

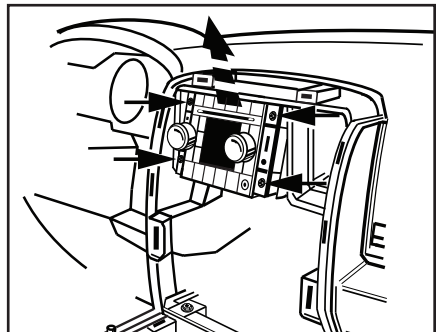

(Figure I)

Jeep Commander/Grand Cherokee 2008-2010

1. Unsnap and remove the small trim around the console shifter. (Figure A)
2. Unsnap and remove the larger trim around the console shifter. (Figure B)
3. Remove (1) Phillips screw from inside the small storage pocket in the lower dash, between the power outlets. (Figure C)
4. Unsnap and remove the dash panel from around the radio (including climate controls). (Figure D)
5. Remove (4) Phillips screws securing the radio. Unplug and remove radio.

Continue to kit assembly

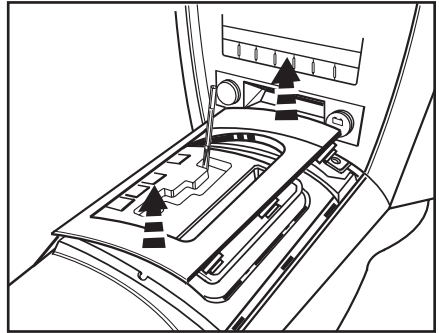

(Figure B)

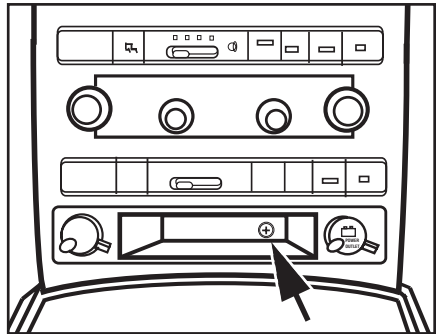

(Figure C)

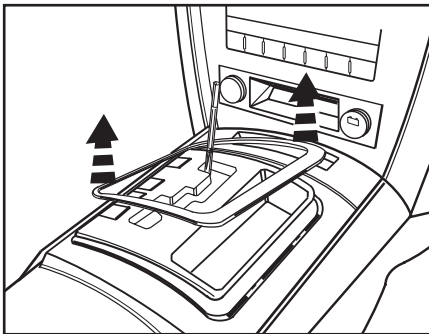

(Figure A)

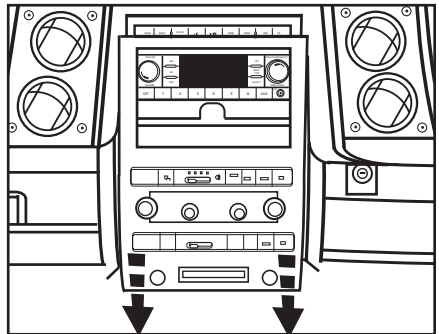

(Figure D)



Dash Disassembly 95-6511

Jeep Wrangler 2007-2010

(Modifications to radio cavity required)

1. Unclip and remove the lower center trim below A/C controls. (Figure A)
2. Remove (2) Phillips screws exposed behind lower center panel. (Figure A)
3. Unclip and remove the upper center trim starting towards the rear of the panel. (Figure A)
4. Remove (2) Phillips screws exposed behind upper center panel. (Figure A)
5. Unclip and remove entire panel surrounding radio and climate controls, including A/C vents.
6. Remove (4) 7 mm screws securing radio. Unplug and remove radio. (Figure B)

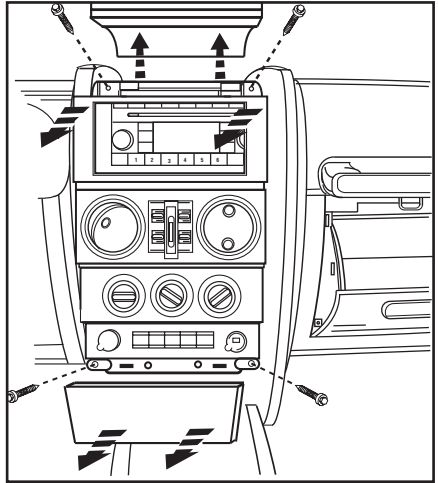

(Figure A)

NOTE: The top of the metal bracket in the sub dash will need to be cut to allow for the clearance of the Double DIN radio's chassis.

Continue to kit assembly

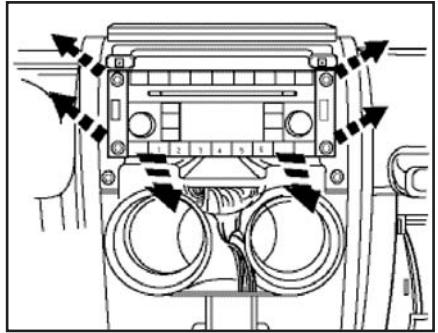

(Figure B)



Dash Disassembly 95-6511

Mitsubishi Raider 2008-2009

1. Unsnap and remove center dash panel.
(Figure A)
2. Remove (4) 7 mm screws securing the radio. Unplug and remove radio.

Continue to kit assembly

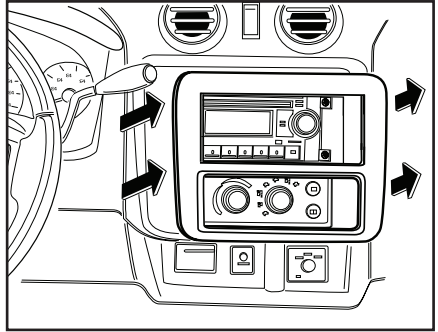

(Figure A)



Kit Assembly 95-6511

Double DIN head unit provision

1. Locate the factory wiring harness in the dash. Metra recommends using the proper mating adapter from Metra or AXXESS. Re-connect the negative battery terminal and test the unit for proper operation.
2. Attach the Double DIN brackets/trim plates to the Double DIN radio using the screws supplied with the radio. (Figure A)
3. Reassemble dash in reverse order of disassembly.

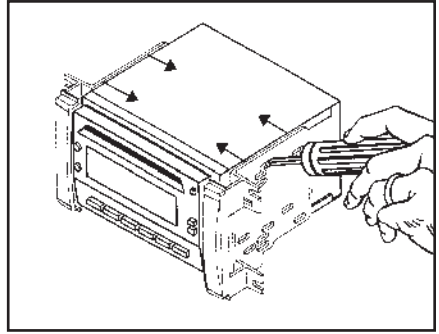

(Figure A)

Stacked ISO head unit provision

1. Locate the factory wiring harness in the dash. Metra recommends using the proper mating adapter from Metra or AXXESS. Re-connect the negative battery terminal and test the unit for proper operation.
2. Attach the Double DIN brackets/trim plates to the stacked ISO units using the screws supplied with the units. (Figure A)
3. Reassemble dash in reverse order of disassembly.

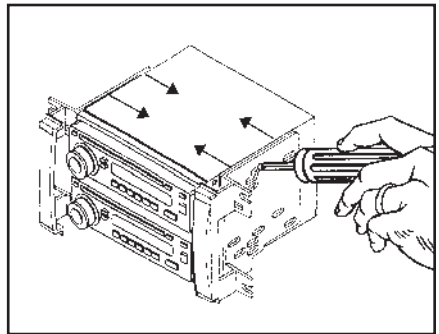

(Figure A)



INSTALLATION INSTRUCTIONS FOR PART 95-6511

REV. 5/17/12 INST95-6511



1-800-221-0932



metraonline.com

© COPYRIGHT 2004-2011 METRA ELECTRONICS CORPORATION



INSTRUCCIONES DE INSTALACIÓN PARA LA PIEZA 95-6511

APLICACIONES

Lista de aplicaciones dentro

Chrysler multi-kit 2007 y mas 95-6511



CARACTERÍSTICAS DEL KIT

- Provisión de unidad central doble DIN
- Provisión de unidad central ISO vertical

COMPONENTES DEL KIT

- A) Soportes doble DIN/placa de moldura

A

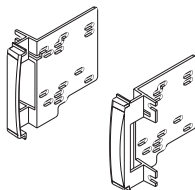

CABLEADO Y CONEXIONES DE ANTENA (se venden por separado)

Arnés de cableado:

- XSVI-6522-NAV - Arnés Chrysler CAN RAP 2007 y mas
- CHTO-03 - Arnés Chrysler CAN con amplificador 2007 y mas

Adaptador de antena:

- 40-EU10 - Adaptador de antena europeo 2002 y mas

HERRAMIENTAS REQUERIDAS

- Herramienta de remoción de panel
- Destornillador Phillips
- Destornillador de hoja plana pequeño
- Conjunto de receptáculo



METRA. THE WORLD'S BEST KITS.™



1-800-221-0932



metraonline.com

© COPYRIGHT 2004-2011 METRA ELECTRONICS CORPORATION

REV. 5/22/12
INST95-6511

REV. 5/22/12
INST95-6511



95-6511

Aplicaciones

Chrysler

200	2011 y mas
300/300C	2008-2010
Aspen	2008-2009
Sebring	2007-2010
Town and Country	2008 y mas

Dodge

Avenger	2007 y mas
Caliber	2009 y mas
Challenger	2008 y mas
Charger	2008-2010

Dodge (seguido)

Dakota	2008-2011
Durango	2008-2010
Grand Caravan	2008 y mas
Journey**	2009-2010
Magnum	2008
Nitro	2007-2011
Ram 1500	2009 y mas
Ram 2500/3500	2010 y mas

Jeep

Compass	2009 y mas
---------	------------

Jeep (seguido)

Commander	2008-2010
Grand Cherokee	2008-2010
Patriot	2009 y mas
Liberty	2008 y mas
Wrangler**	2007-2010

Mitsubishi

Raider	2008-2009
--------	-----------

VW

Routan	2009 y mas
--------	------------

** (Modificaciones a la cavidad de radio requerido)

PRECAUCIÓN: Metra recomienda desconectar el terminal negativo de la batería antes de comenzar cualquier instalación. Todos los accesorios, interruptores y, especialmente, las luces indicadoras de airbag deben estar enchufados antes de volver a conectar la batería o comenzar el ciclo de ignición.

Nota: Remítase a las instrucciones incluidas con el radio de posventa.



EL CONOCIMIENTO ES PODER

Mejore sus habilidades de instalación y fabricación inscribiéndose en la escuela de dispositivos electrónicos móviles más reconocida y respetada de nuestra industria. Regístrese en www.installerinstitute.com o llame al 800-354-6782 para obtener más información y avance hacia un futuro mejor.



Metra recomienda técnicos con certificación del Programa de Certificación en Electrónica Móvil (Mobile Electronics Certification Program, MECP).



95-6511

Indice

Desmontaje del tablero

– Chrysler Aspen 2008-2009/Dodge Durango 2008-2010	4
– Chrysler Sebring 2007-2010	5
– Chrysler Town and Country 2008-2010.....	6-7
– Chrysler Town and Country 2011 y mas.....	8
– Chrysler 200 2011 y mas	9
– Chrysler 300/300c 2008-2010	10
– Dodge Magnum 2008/Charger 2008-2010	10
– Dodge Avenger 2007 y mas.....	11
– Dodge Dakota 2008-2011	12
– Dodge Nitro 2007-2011/Jeep Liberty 2008 y mas	13
– Dodge Journey 2009-2010**	14
– Dodge Caliber 2009 y mas.....	15
– Dodge Challenger 2009 y mas.....	15
– Dodge Grand Caravan 2008-2010	6-7
– Dodge Grand Caravan 2011 y mas.....	8
– Dodge Ram 1500 2009 y mas	16-18
– Dodge Ram 2500/3500 2010 y mas	16-18
– Jeep Compass 2009 y mas.....	15
– Jeep Patriot 2009 y mas.....	15
– Jeep Commander/Grand Cherokee 2008-2010.....	19
– Jeep Wrangler 2007-2010**	20
– Mitsubishi Raider 2008-2009	21
– VW Routan 2009 y mas.....	8

Ensamble del kit

– Provisión de unidad central doble DIN	22
– Provisión de unidad central ISO vertical	22

** (Modificaciones a la cavidad de radio requerido)

Chrysler Aspen 2008-2009 Dodge Durango 2008-2010

1. Suelte a presión y retire el ensamble de almacenamiento/portavasos. (Figura A)
2. Retire los (2) tornillos del borde inferior del panel de la moldura del tablero central. Suelte y retire el panel. (Figura B)
3. Retire los (4) tornillos que sostienen el radio. Desconecte y retire el radio. (Figura C)

Continuará al ensamble del kit

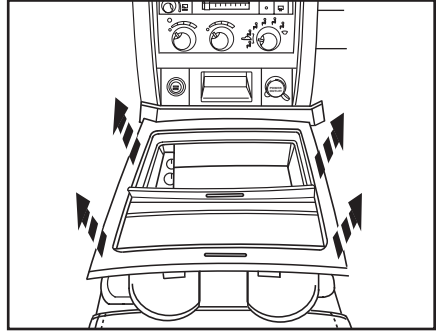

(Figura A)

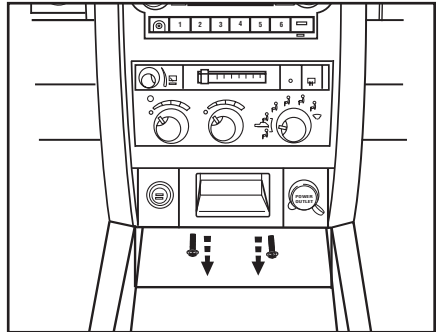

(Figura B)

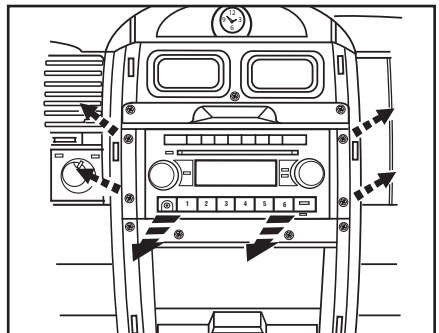

(Figura C)

Chrysler Sebring 2007-2010

1. Desenganche todo el panel que rodea el radio, incluyendo las rejillas del aire acondicionado y el reloj. Desconecte y retire el panel. (Figura A)
2. Retire los (4) tornillos de 7 mm que sostienen el radio. Desconecte y retire el radio. (Figura B)

Continuará al ensamble del kit

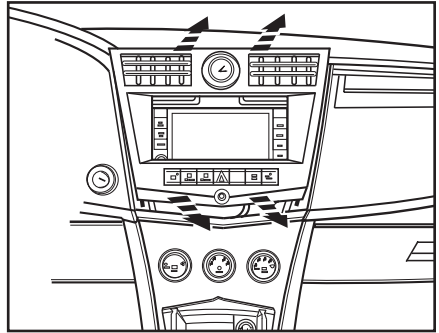

(Figura A)

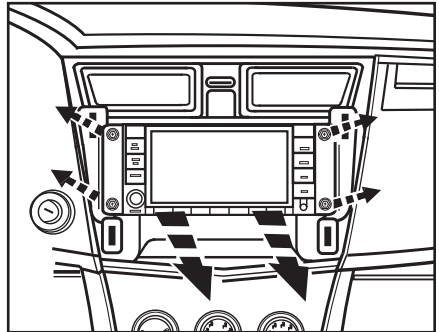

(Figura B)

Chrysler Town and Country 2008-2010 Dodge Grand Caravan 2008-2010

1. Retire las (2) tapas de los tornillos orientadas hacia arriba sobre el radio, luego retire los (2) tornillos Phillips expuestos. (Figura A)
2. Levante el panel de arriba del radio y luego retire los (2) tornillos Phillips expuestos en el borde frontal del panel de la moldura del radio. (Figura B)
3. Retire las (3) chinchetas de plástico por lado del panel de la moldura inferior y luego del panel lateral hacia la parte trasera de la van para obtener acceso a los (2) tornillos de la parte inferior del panel de la moldura del radio. (Figura C)

Continúa en la página

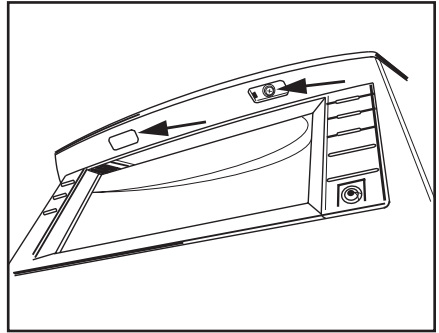

(Figura A)

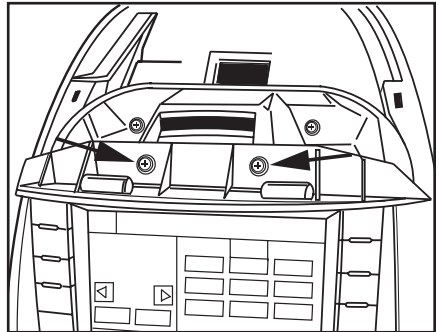

(Figura B)

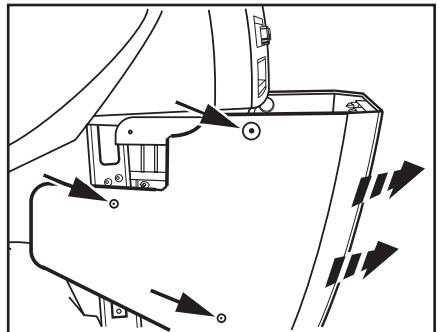

(Figura C)

Chrysler Town and Country 2008-2010 Dodge Grand Caravan 2008-2010

4. Retire los (2) tornillos Phillips expuestos del panel de la moldura del radio del borde inferior. (Figura D)
5. Desenganche y retire todo el panel que rodea el radio, incluyendo los controles del clima, las rejillas y el reloj. (Figura E)
6. Retire los (4) tornillos Phillips que sostienen el radio. (Figura F)

Continuará al ensamble del kit

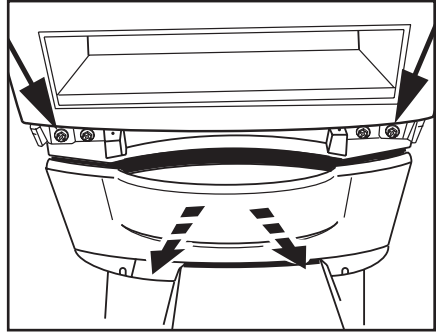

(Figura D)

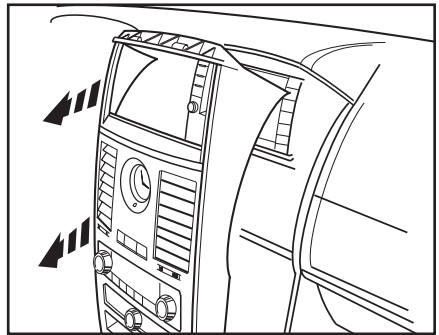

(Figura E)

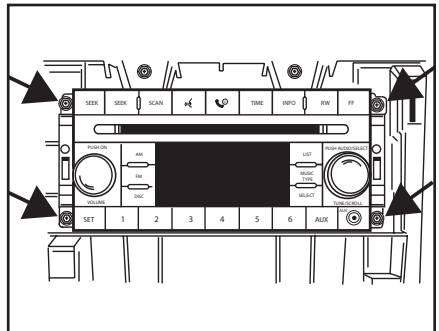

(Figura F)

Chrysler Town and Country 2011 y mas Dodge Grand Caravan 2011 y mas Volkswagen Routan 2009 y mas

1. Desenganche y retire el panel de moldura para radio. (Figura A)
2. Retire los (4) tornillos Torx que sostienen el radio. (Figura B)

Continuará al ensamble del kit

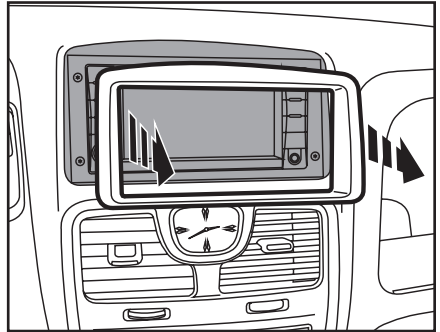

(Figura A)

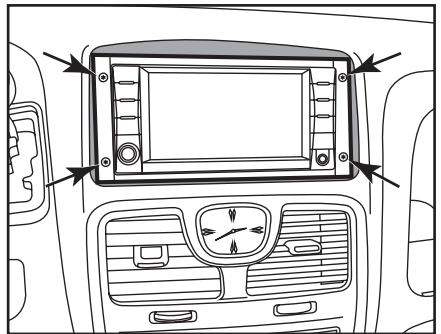

(Figura B)

Chrysler 200 2011 y mas

1. Desenganche y retire el panel de moldura para radio. (Figura A)
2. Retire los (4) tornillos Torx que sostienen el radio. (Figura B)

Continuará al ensamble del kit

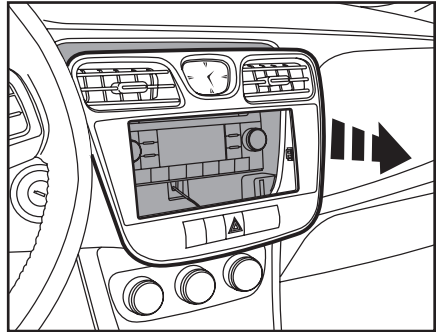

(Figura A)

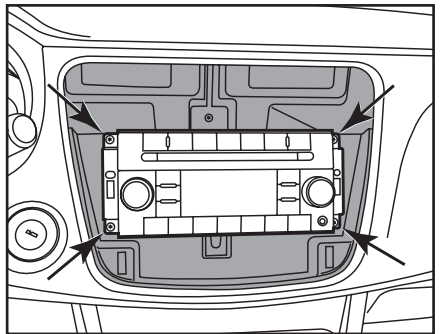

(Figura B)

Chrysler 300/300C 2008-2010 Dodge Magnum 2008 Dodge Charger 2008-2010

1. Suelte a presión y retire el panel de la moldura del tablero central. (Figura A)
2. Retire los (4) tornillos que sostienen el radio. Desconecte y retire el radio. (Figura B)

Continuará al ensamble del kit

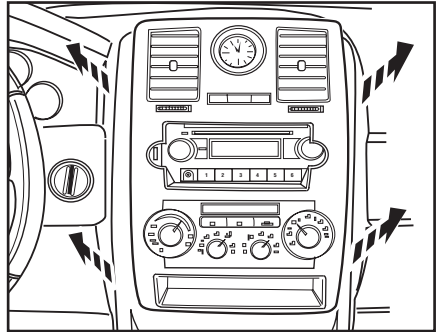

(Figura A)

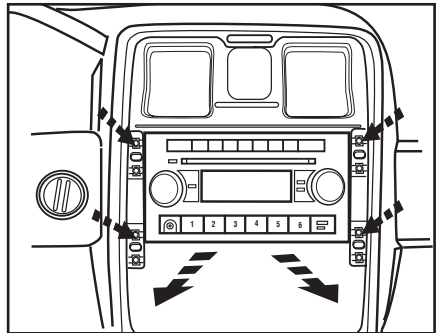

(Figura B)

Dodge Avenger 2007 y mas

1. Desenganche y retire el panel de la moldura de la consola central. (Figura A)
2. Desenganche el panel de la moldura del tablero central. (Figura B)
3. Retire los (4) tornillos que sostienen el radio. Desconecte y retire el radio. (Figura C)
4. Retire los (3) tornillos que sujetan el soporte de apoyo trasero del radio y retire el soporte. (Figura D)

Continuará al ensamble del kit

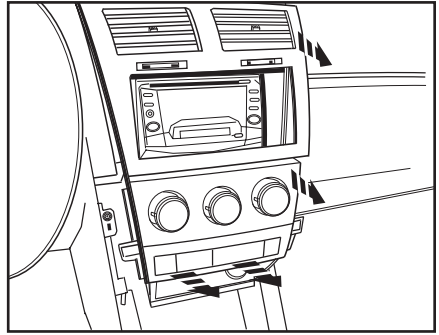

(Figura B)

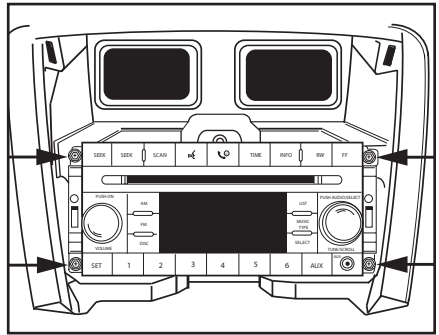

(Figura C)

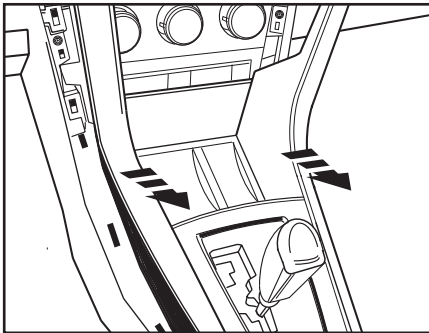

(Figura A)

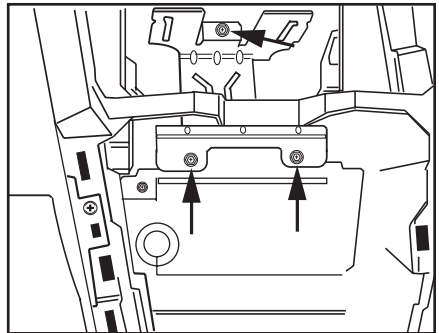

(Figura D)

Dodge Dakota 2008-2011

1. Desenganche y retire el panel de moldura que rodea el radio. (Figura A)
2. Retire los (4) tornillos Phillips que sostienen el radio. (Figura B)

Continuará al ensamble del kit

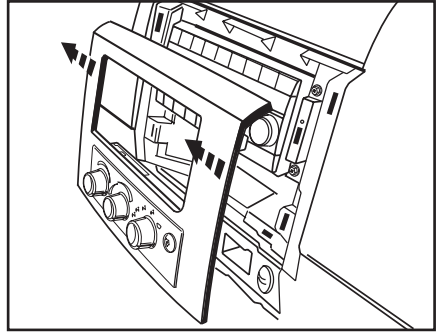

(Figura A)

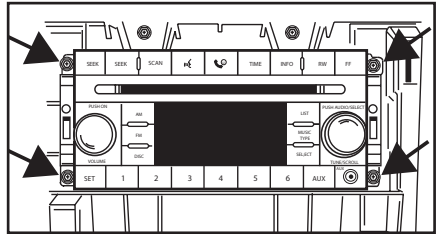

(Figura B)

Dodge Nitro 2007-2011 Jeep Liberty 2008 y mas

1. Desenganche todo el panel que rodea el radio y los controles del clima, incluyendo las rejillas del aire acondicionado. Desconecte y retire el panel. (Figura A)
2. Retire los (4) tornillos de 7 mm que sostienen el radio. Desconecte y retire el radio. (Figura B)

Continuará al ensamble del kit

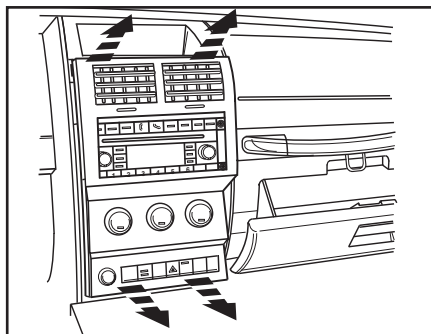

(Figura A)

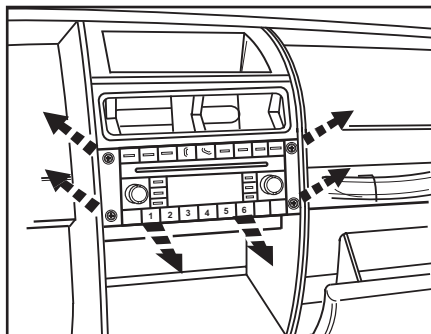

(Figura B)

Dodge Journey 2009-2010

(Modificaciones a la cavidad de radio requerido)

1. Desenganche y retire todo el panel de la moldura del radio de fábrica, incluyendo los controles del aire acondicionado. (Figura A)

Sugerencia: Abra la puerta del compartimiento de la parte superior del panel de la moldura del radio.

2. Retire los (4) tornillos de 7 mm que sujetan el radio al tablero y retire. (Figura B)

Nota: La parte superior del soporte metálico del sub tablero tendrá que cortarse para permitir que haya suficiente espacio para el chasis del radio doble DIN. (Figura C)

Continuará al ensamble del kit

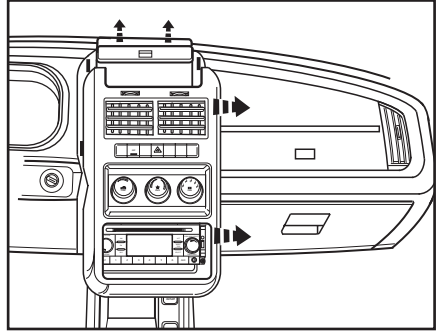

(Figura A)

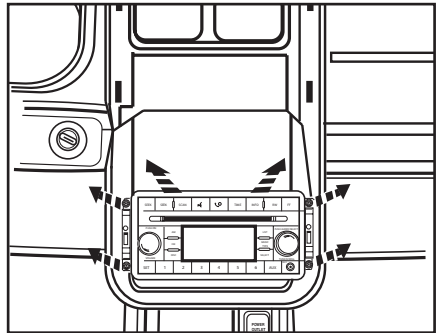

(Figura B)

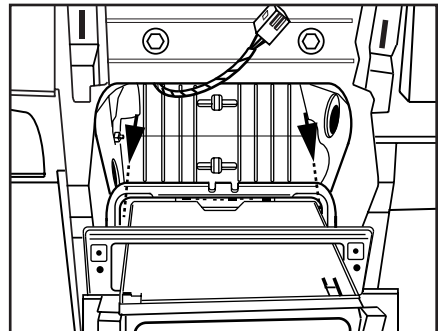

(Figura C)

Dodge Caliber 2009 y mas Dodge Challenger 2009 y mas Jeep Compass 2009 y mas Jeep Patriot 2009 y mas

1. Suelte y mueva la moldura de la palanca de velocidades a un lado. (Figura A)
2. Suelte el panel de la moldura del tablero central (no lo retire hasta que se hayan retirado los controles de clima). (Figura A)
3. Retire los (4) tornillos Phillips que sostienen el panel de control de clima a la parte posterior del panel del tablero central.
4. Retire los (4) tornillos de 7 mm que sostienen el radio. Desconecte y retire el radio.
5. El soporte metálico del sub tablero tendrá que retirarse por la profundidad del radio doble DIN de mercado secundario.

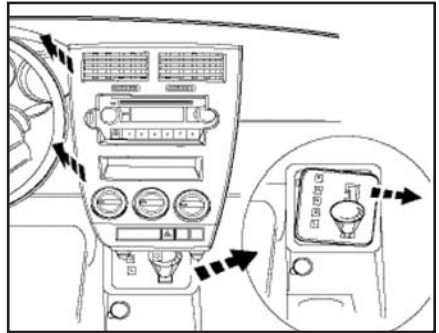

(Figura A)

Continuará al ensamble del kit

Dodge Ram 1500 2009 y mas Dodge Ram 2500/3500 2010 y mas

1. Retire (1) tornillo Torx T25 del compartimiento junto a los portavasos. (Figura A)
2. Retire los (2) tornillos Phillips de la cavidad debajo del control de clima al frente de la consola central. (Figura B)
3. Retire los (2) tornillos de 9/32" de los portavasos. (Figura C)

Continúa en la página

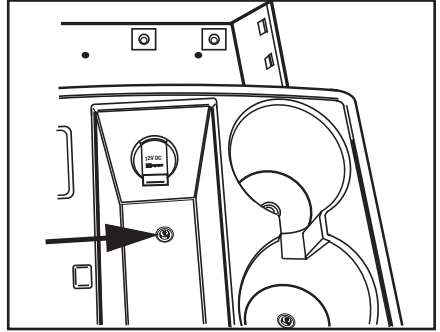

(Figura A)

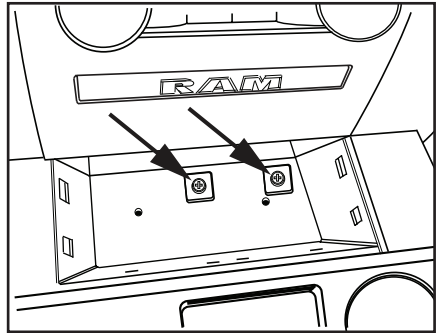

(Figura B)

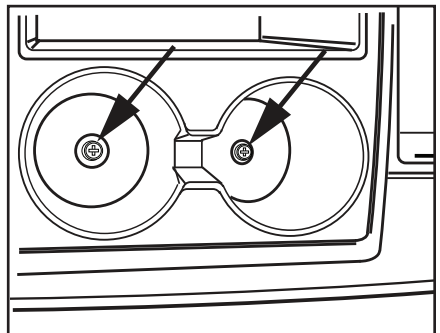

(Figura C)

Dodge Ram 1500 2009 y mas Dodge Ram 2500/3500 2010 y mas

4. Empuje hacia abajo el collar debajo de la palanca de velocidades, luego jale la palanca en línea recta hacia arriba para retirarla. (Figura D)
5. Desenganche y retire la parte superior de la consola central, incluyendo los portavasos. (Figura E)
6. Desenganche y retire el panel de la moldura del receptáculo de accesorios en el panel de la moldura del radio, luego retire (1) tornillo Torx T25. (Figura F)

Continúa en la página

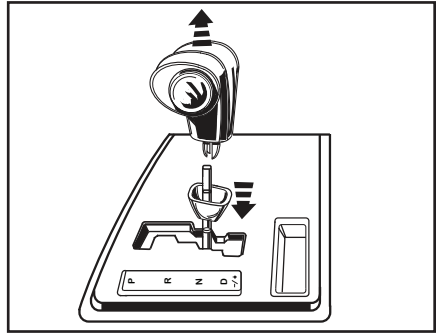

(Figura D)

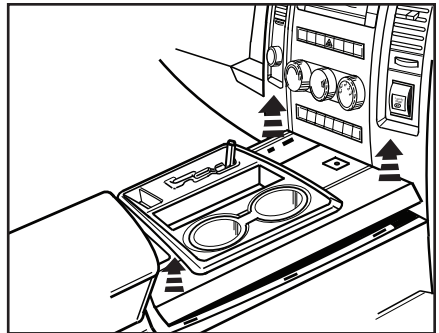

(Figura E)

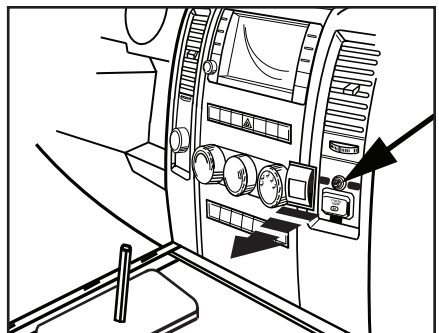

(Figura F)

Dodge Ram 1500 2009 y mas Dodge Ram 2500/3500 2010 y mas

7. Retire los (2) tornillos Torx T25 de la parte superior del panel de la moldura del tablero. (Figura G)
8. Desenganche y retire todo el panel de la moldura del radio, incluyendo los controles del clima. (Figura H)
9. Retire los (4) tornillos de 9/32" que sostienen el radio. (Figura I)

Continuará al ensamble del kit

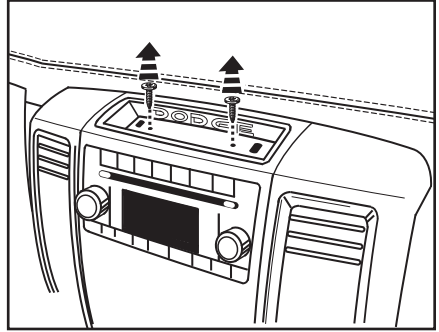

(Figura G)

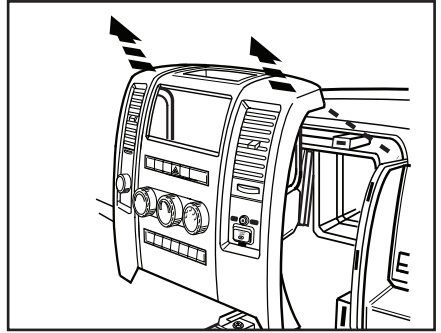

(Figura H)

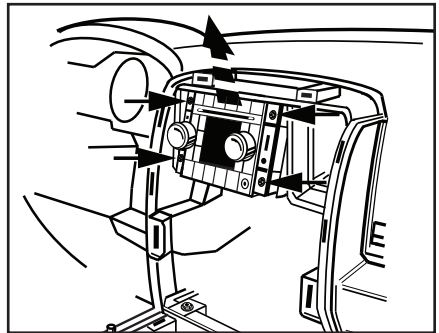

(Figura I)

Jeep Commander/Grand Cherokee 2008-2010

1. Suelte a presión y retire la moldura pequeña de alrededor de la palanca de velocidades de la consola. (Figura A)
2. Suelte a presión y retire la moldura más grande alrededor de la palanca de velocidades de la consola. (Figura B)
3. Retire (1) tornillo Phillips del interior de la pequeña cavidad de almacenamiento del tablero inferior, entre los tomacorrientes. (Figura C)
4. Suelte a presión y retire el panel del tablero de alrededor del radio (incluyendo los controles del clima). (Figura D)
5. Retire los (4) tornillos Phillips que sostienen el radio. Desconecte y retire el radio.

Continuará al ensamble del kit

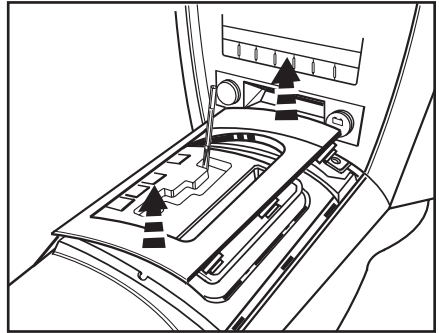

(Figura B)

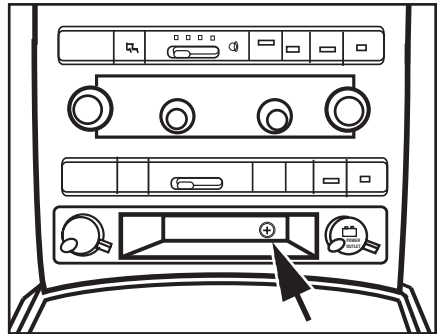

(Figura C)

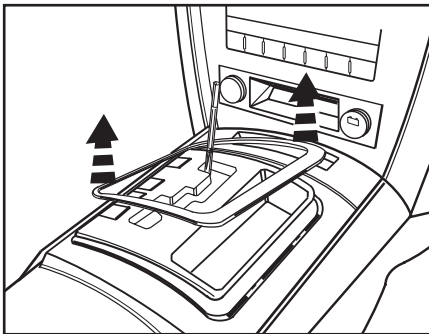

(Figura A)

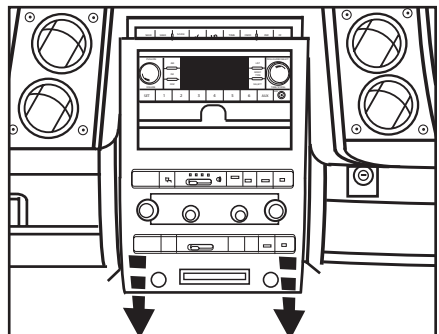

(Figura D)

Jeep Wrangler 2007-2010

(Modificaciones a la cavidad de radio requerido)

1. Desenganche y retire la moldura central inferior debajo de los controles del aire acondicionado. (Figura A)
2. Retire los (2) tornillos Phillips expuestos detrás del panel central inferior. (Figura A)
3. Desenganche y retire la moldura central superior, empezando hacia la parte trasera del panel. (Figura A)
4. Retire los (2) tornillos Phillips expuestos detrás del panel central superior. (Figura A)
5. Desenganche y retire todo el panel que rodea el radio y los controles del clima, incluyendo las rejillas del aire acondicionado.
6. Retire los (4) tornillos de 7 mm que sostienen el radio. Desconecte y retire el radio. (Figura B)

Nota: La parte superior del soporte metálico del sub tablero tendrá que cortarse para permitir que haya suficiente espacio para el chasis del radio doble DIN.

Continuará al ensamble del kit

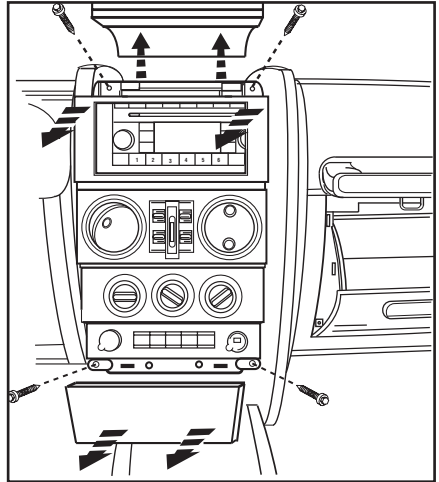

(Figura A)

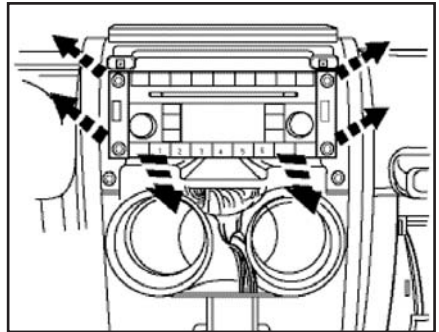

(Figura B)

Mitsubishi Raider 2008-2009

1. Suelte y retire el panel del tablero central. (Figura A)
2. Retire los (4) tornillos de 7 mm que sostienen el radio. Desconecte y retire el radio.

Continuará al ensamble del kit

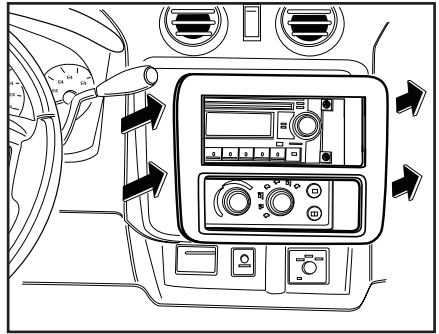

(Figura A)

Provisión de unidad central doble DIN

1. Ubique el arnés del cableado de fábrica en el tablero. Metra recomienda usar el adaptador de acoplamiento adecuado de Metra o AXCESS. Vuelva a conectar el terminal negativo de la batería y pruebe la unidad para verificar que funcione correctamente.
2. Una los soportes doble DIN/las placas de moldura al radio doble DIN con los tornillos suministrados con el radio. (Figura A)
3. Vuelva a montar el tablero en forma inversa al desmontaje.

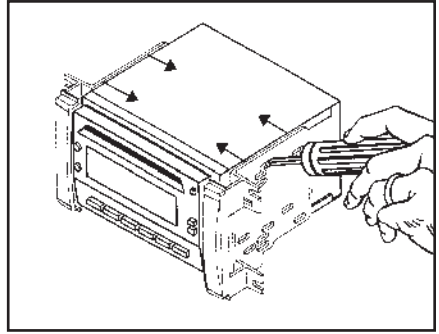

(Figura A)

Provisión de unidad central ISO vertical

1. Ubique el arnés del cableado de fábrica en el tablero. Metra recomienda usar el adaptador de acoplamiento adecuado de Metra o AXCESS. Vuelva a conectar el terminal negativo de la batería y pruebe la unidad para verificar que funcione correctamente.
2. Una los soportes doble DIN/las placas de moldura a las unidades ISO verticales con los tornillos suministrados con las unidades. (Figura A)
3. Vuelva a montar el tablero en forma inversa al desmontaje.

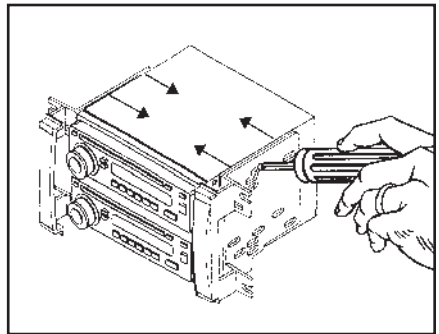

(Figura A)



INSTRUCCIONES DE INSTALACIÓN PARA LA PIEZA 95-6511

REV. 5/22/12 INST95-6511



1-800-221-0932



metraonline.com

© COPYRIGHT 2004-2011 METRA ELECTRONICS CORPORATION